

PÁNELES PREFABRICADOS

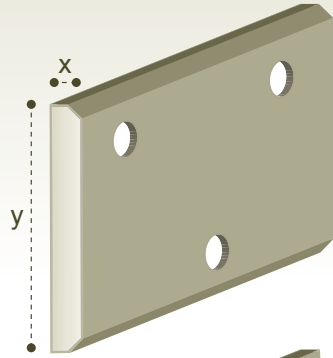

Flexipanel

CLAVE	ANCHO (x)	ALTO (y)
FXP-171	1 ½"	12"
FXP-172	1 ½"	16"
FXP-173	1 ½"	24"

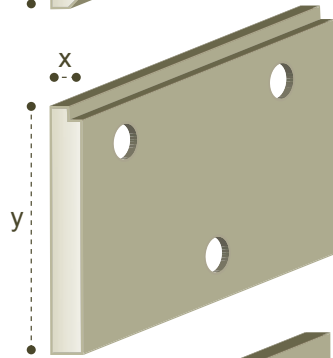

Flexipanel

CLAVE	ANCHO (x)	ALTO (y)
FXP-181	1 ½"	12"
FXP-182	1 ½"	16"
FXP-183	1 ½"	24"

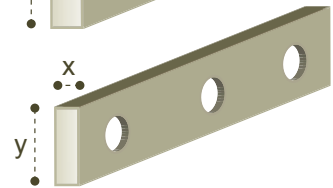

Flexitrim

CLAVE	ANCHO (x)	ALTO (y)
FXP-191	1 ½"	4"

Recomendación para el uso de sujetadores mecánicos

